



RAYSTAR

曜凌光電股份有限公司

住址: 42878 台中市大雅区科雅路 25 號 5F WEB: <http://www.Raystar-Optronics.com>
5F., No.25, Keya Rd., Daya Dist., Taichung E-mail: sales@raystar-optronics.com
City 428, Taiwan Tel:886-4-2565-0761 Fax :
886-4-2565-0760

RFF70A-EIW-D

SPECIFICATION

CUSTOMER:

APPROVED BY	
PCB VERSION	
DATE	

FOR CUSTOMER USE ONLY

SALES BY	APPROVED BY	CHECKED BY	PREPARED BY

ISSUED DATE:

Contents

	Page
1. Revision History	3
2. General Specification	4
3. Module Coding System	5
4. Interface Pin Function	6
5. Outline dimension & Block Diagram	7
6. Display Control Instruction	10
7. Optical Characteristics	11
8. Absolute Maximum Ratings	14
9. Electrical Characteristics	16
10. Backlight Information	22
11. Reliability Test	23

1. Revision History

DATE	VERSION	REVISED PAGE NO.	Note
2009/10/8	1		First issue
2012/09/13	2	10&16~20	Correct AC Characteristics &Data transfer order Setting
		6	Modify PIN
		4	Add Gray Scale Inversion Direction

RAYSTAR OPTRONICS

2. General Specification

This technical specification applies to 7" TFT-LCD module with a LED Backlight unit and a 40-pin TTL interface. This module supports 800*R.G.B x 480 WVGA mode and can display 262,144 colors.

- Dot Matrix: 800xRGBx 480
- Module dimension: 165.0x 104.44 x 5.7(max.) mm³
- Active Area : 152.4x 91.44 mm²
- Pixel Size:190.5 x 190.5 um
- LCD type: TFT, Negative, Transmissive
- View direction: 12 o'clock
- Gray Scale Inversion Direction: 6 o'clock
- Backlight Type: LED, Normally White

3. Module Coding System

R	F	F	70	A	-	E	I	W	-	D
1	2	3	4	5	-	6	7	8	-	9

Item	Description		
1	R : Raystar Optronics Inc.		
2	Display Type : TFT Type		
3	Solution: A: 128x160 B:320x234 C:320x240 D:480x234 F:800x480		
4	Display Size : 7.0" TFT		
5	Version Code.		
6	Model serials no.		
7	Polarizer Type, Temperature range, View direction	A : Reflective, N.T, 6:00	K : Transflective, W.T,12:00
		D : Reflective, N.T, 12:00	1 : Transflective, U.T,6:00
		G : Reflective, W. T, 6:00	4 : Transflective, U.T.12:00
		J : Reflective, W. T, 12:00	C : Transmissive, N.T,6:00
		0 : Reflective, U. T, 6:00	F : Transmissive, N.T,12:00
		3 : Reflective, U. T, 12:00	I : Transmissive, W. T, 6:00
		B : Transflective, N.T,6:00	L : Transmissive, W.T,12:00
		E : Transflective, N.T.12:00	2 : Transmissive, U. T, 6:00
		H : Transflective, W.T,6:00	5 : Transmissive, U.T,12:00
8	Backlight	N : Without backlight	Y : LED, Yellow Green
		P : EL, Blue green	A : LED, Amber
		T : EL, Green	W : LED, White
		D : EL, White	O : LED, Orange
		F : CCFL, White	G : LED, Green
9	Driver Method	D: Digital A: Analog	

4. Interface Pin Function

LCM PIN Definition

Pin No.	Symbol	Pin No.	Symbol
1	GND	16	NC
2	VDD	17	NC
3	NC	18	RST
4	A0	19	NC
5	R/W	20	NC
6	E		
7	DB0		
8	DB1		
9	DB2		
10	DB3		
11	DB4		
12	DB5		
13	DB6		
14	DB7		
15	CS		

LED BACKLIGHT (CN2): JST BHSR-02VS-1

Pin No.	Symbol
1	A
2	K

CORRESPONDABLE BACKLIGHT CONNECTOR : SM 02B-BHSS-1

5. Outline Dimension & Block Diagram

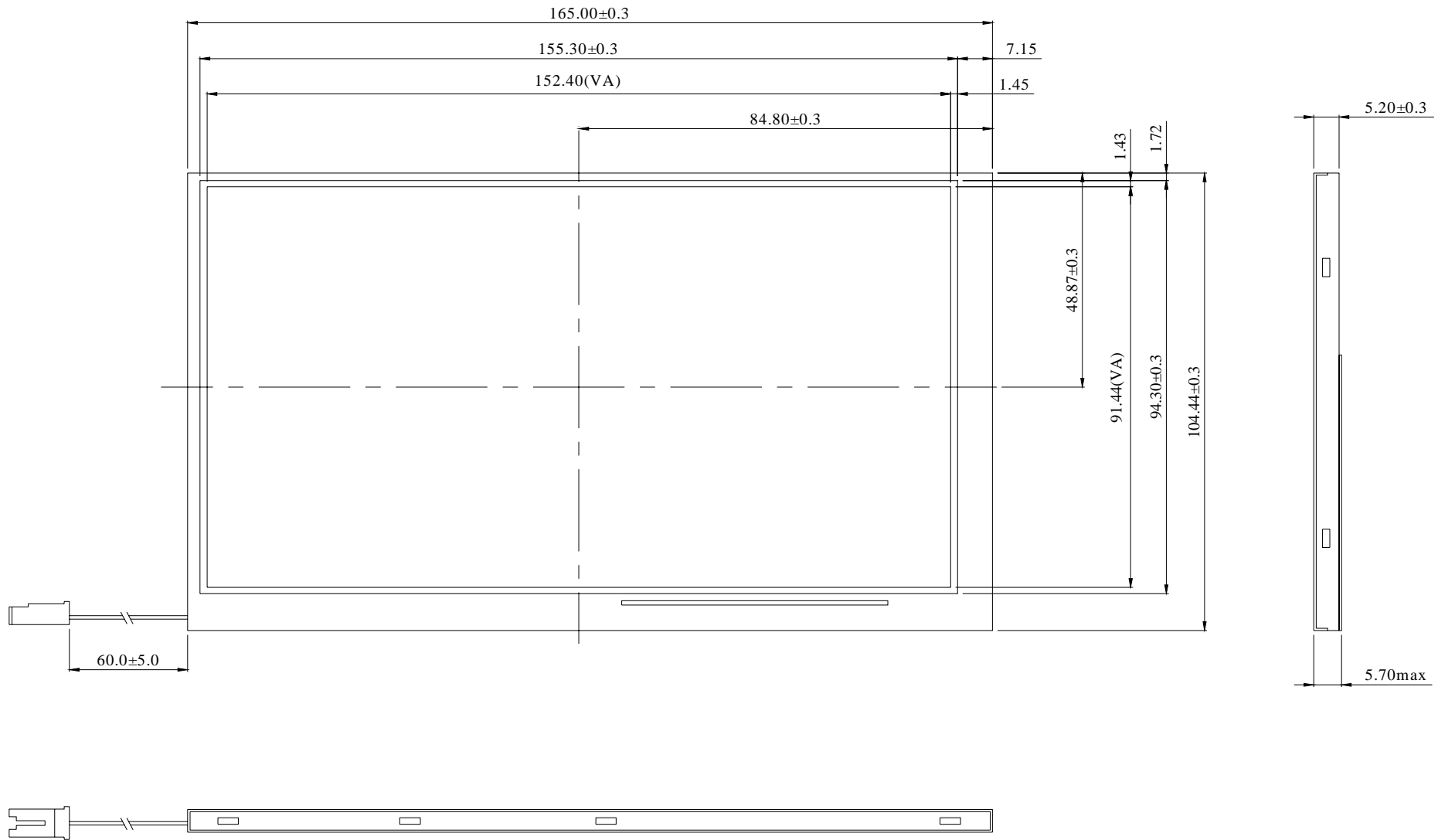

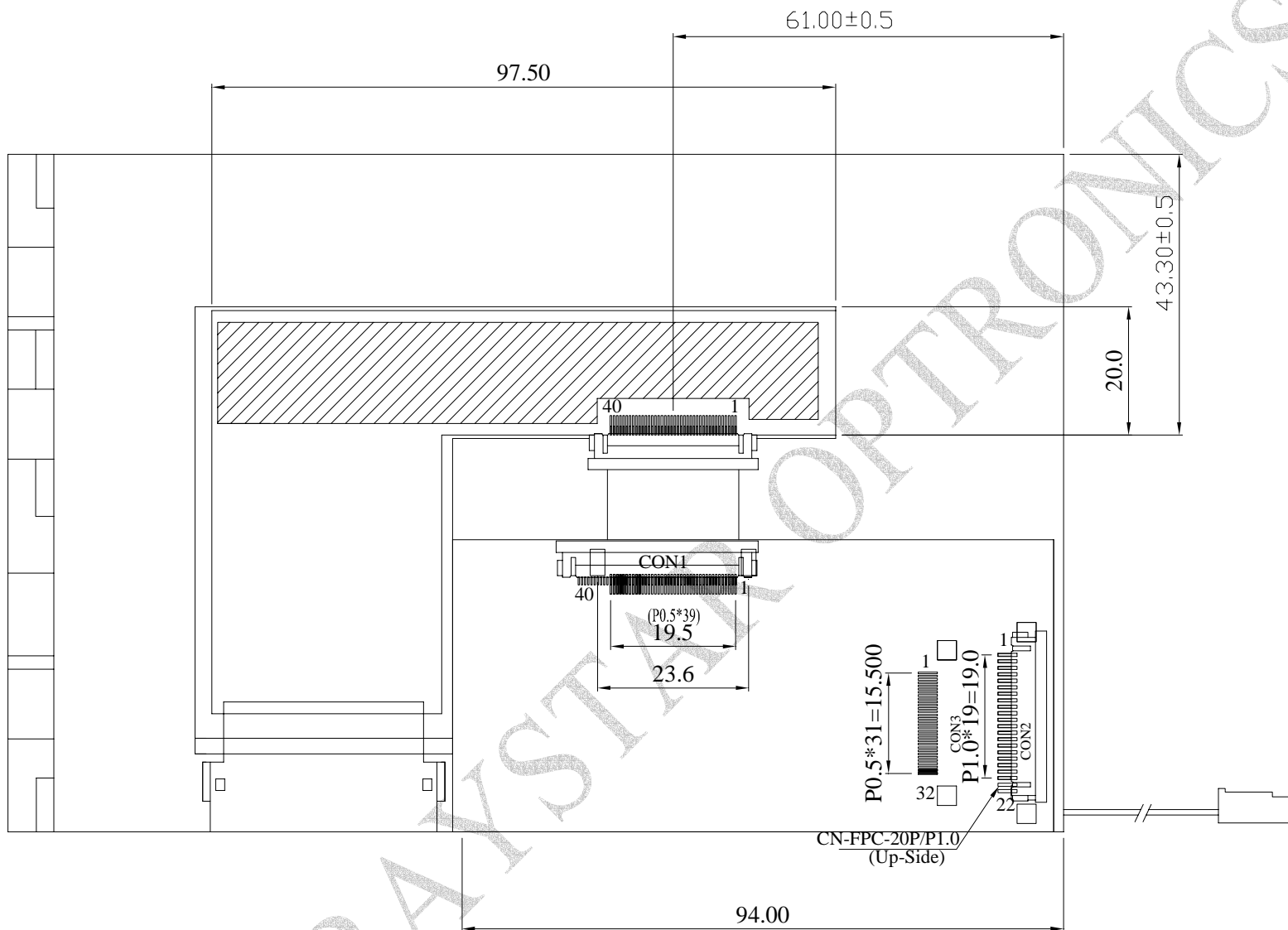

PIN NO.	SYMBOL
1	GND
2	VDD
3	NC
4	A0
5	R/W
6	E
7	DB0
8	DB1
9	DB2
10	DB3
11	DB4
12	DB5
13	DB6
14	DB7
15	CS
16	NC
17	NC
18	RST
19	NC
20	NC

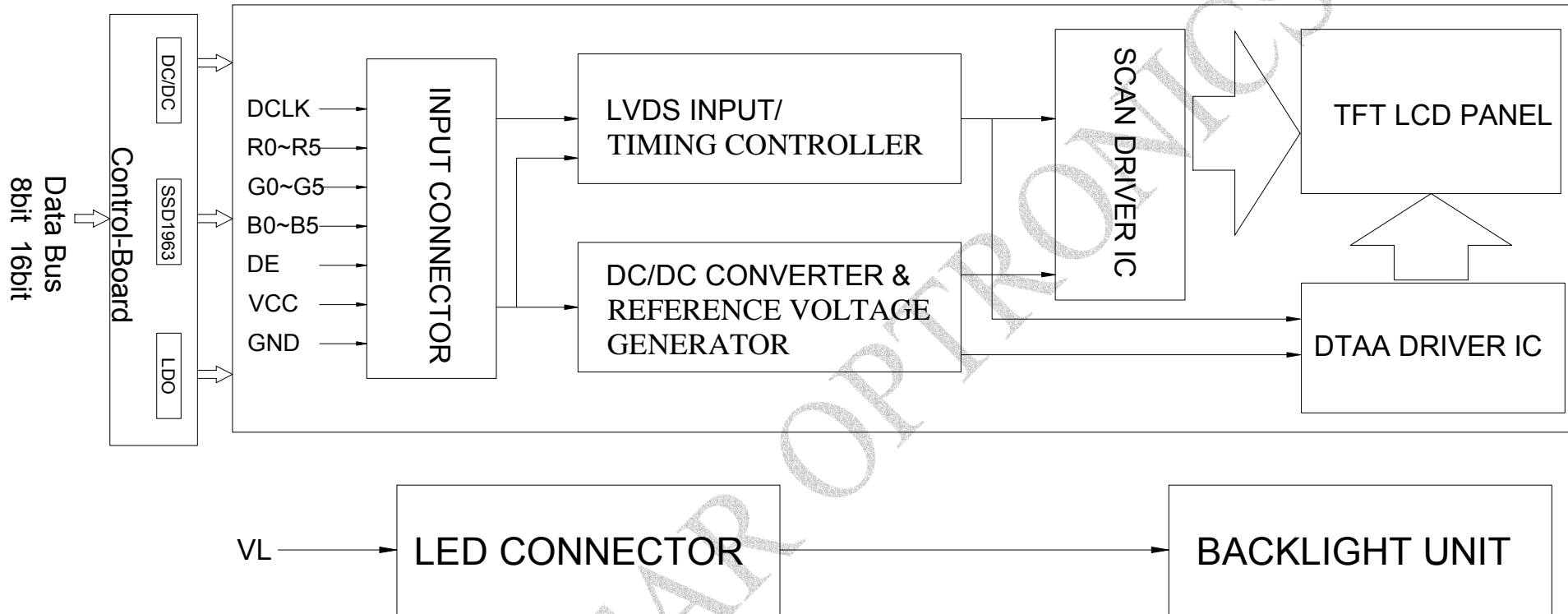

6. Display Control Instruction

6.1 Data transfer order Setting

Pixel Data Format

Pixel Data Format

Both 6800 and 8080 support 8-bit, 9-bit, 16-bit, 18-bit and 24-bit data bus. Depending on the width of the data bus, the display data are packed into the data bus in different ways.

Table 6-1: Pixel Data Format

Interface	Cycle	D[23]	D[22]	D[21]	D[20]	D[19]	D[18]	D[17]	D[16]	D[15]	D[14]	D[13]	D[12]	D[11]	D[10]	D[9]	D[8]	D[7]	D[6]	D[5]	D[4]	D[3]	D[2]	D[1]	D[0]
24 bits	1st	R7	R6	R5	R4	R3	R2	R1	R0	G7	G6	G5	G4	G3	G2	G1	G0	B7	B6	B5	B4	B3	B2	B1	B0
	1st																								
18 bits	1st																								
16 bits (565 format)	1st																								
	1st																								
16 bits	1st																								
	1st																								
16 bits	2nd																								
	3rd																								
12 bits	1st																								
	2nd																								
9 bits	1st																								
	2nd																								
8 bits	1st																								
	2nd																								
	3rd																								

6.2 Register Depiction

Please consult the spec of SSD1963

7. OPTICAL CHARACTERISTIC

Item	Symbol	Condition	Min.	Typ.	Max.	Unit	Remark
Brightness	-	Viewing normal angle $\theta = \phi = 0$	300	350	-	cd/m ²	Center of display
Response time	Tr		-	5	10	.ms	Note 3,5
	Tf		-	11	16	.ms	
Contrast ratio	CR		250	400	-	-	Note 4,5
Color Chromaticity	White		Wx	0.249	0.299	0.349	-
		Wy	0.278	0.328	0.378		
Viewing angle	Hor.	θ_R	60	70	-	Deg.	Note 1
		θ_L	60	70	-		
	Ver.	ϕ_T	50	60	-		
		ϕ_B	60	70	-		

Note 1: Definition of viewing angle range

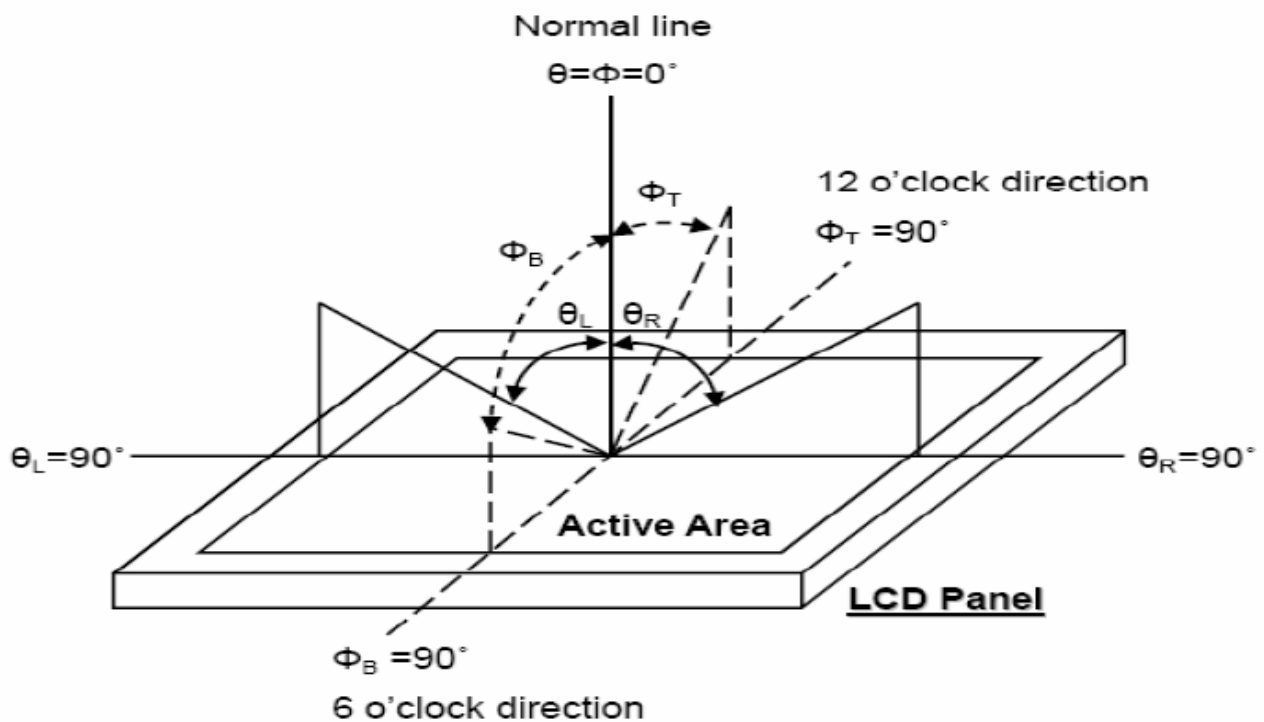

Definition of viewing angle

Note 2: Test equipment setup:

After stabilizing and leaving the panel alone at a driven temperature for 10 minutes, the measurement should be executed. Measurement should be executed in a stable, windless, and dark room. Optical specifications are measured by Topcon BM-7 luminance meter 1.0° field of view at a distance of 50cm and normal direction.

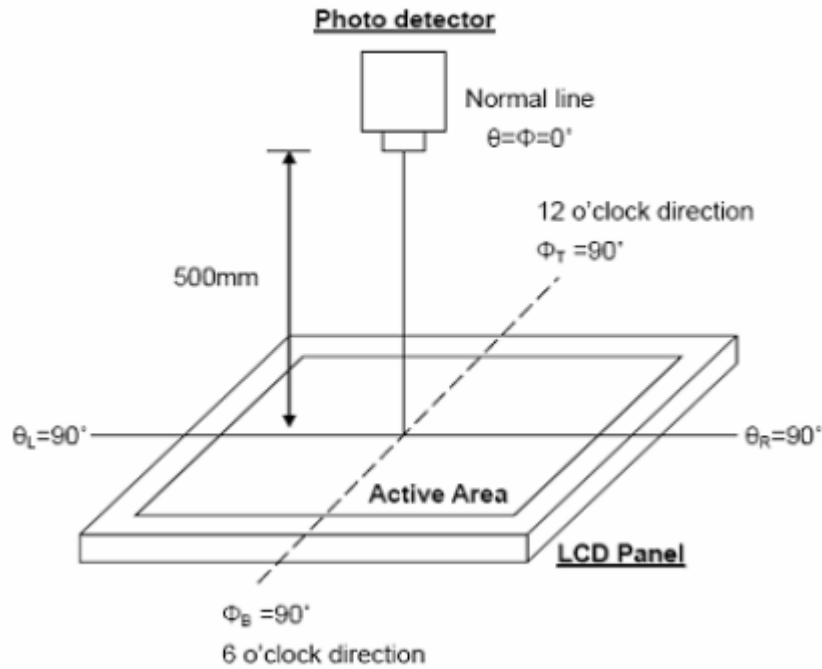

Optical measurement system setup

Note 3: Definition of Response time:

The response time is defined as the LCD optical switching time interval between “White state and “Black” state. Rise time, T_r , is the time between photo detector output intensity changed from 90% to 10% . And fall time, T_f , is the time between photo detector output Intensity changed from 10% to 90% .

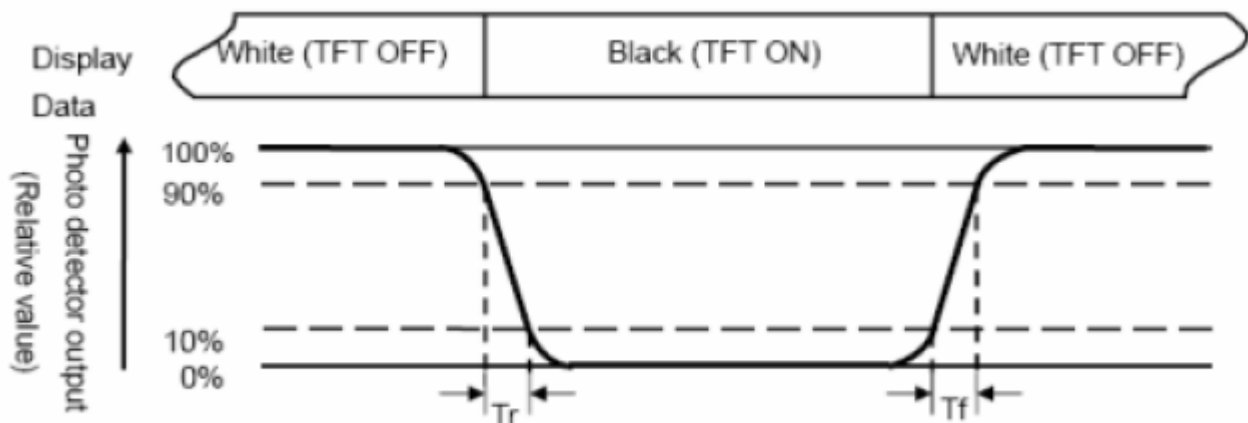

Fig. 3-3 Definition of response time

Note 4: Definition of contrast ratio:

The contrast ratio is defined as the following expression.

$$\text{Contrast ratio (CR)} = \frac{\text{Luminance measured when LCD on the "White" state}}{\text{Luminance measured when LCD on the "Black" state}}$$

Note 5: White $V_i = V_{i50} \pm 1.5V$

Black $V_i = V_{i50} \pm 2.0V$

“±” means that the analog input signal swings in phase with VCOM signal.

“±” means that the analog input signal swings out of phase with VCOM signal.

The 100% transmission is defined as the transmission of LCD panel when all the input terminals of module are electrically opened.

Note 6: Definition of color chromaticity (CIE 1931)

Color coordinates measured at the center point of LCD

Note 7: Measured at the center area of the panel when all the input terminals of LCD panel are electrically opened.

$$\text{Note 8 : Uniformity (U)} = \frac{\text{Brightness (min)}}{\text{Brightness (max)}} \times 100\%$$

8. Absolute Maximum Ratings

8-1. ENVIRONMENTAL ABSOLUTE MAXIMUM RATINGS

ITEM	WIDE TEMP			
	OPERSTING		STORAGE	
	MIN.	MAX.	MIN.	MAX.
Ambient Temperature(°C)	-20	70	-30	80
Humidity (Without Condensation)	Note 2,4		Note 3,4	

Note 2 $T_a \leq 70^\circ\text{C}$:75%RH MAX.

Note 3 Please refer to item of reliability test.

Note 4 Background color will change slightly depending on ambient temperature.

That phenomenon is reversible.

9. Electrical Characteristics

9-1. ELECTRICAL CHARACTERISTICS OF LCM

ITEM	SYMBOL	CONDITION	MIN.	TYP.	MAX.	UNIT
Power supply for logic	VDD	VDD-DGND	3.0	3.3	3.6	V
Output voltage	VOH	Output high voltage	0.8VDD			
	VOL	Output low voltage			0.2VDD	
Input Voltage	VIH	Input high voltage	0.8VDD	—	VDD +0.5	V
	VIL	Input low voltage			0.2VDD	
Recommended TFT Driving Current for 25°C	I _{VDD}	VDD=3.3V	—	200	260	mA
Brightness	L	I _{AK} =160mA Pattern :All on (White Color)	300.0	350.0	—	cd/m ²

AC Characteristics

Conditions:

Voltage referenced to VSS

VDDD, VDDPLL = 1.2V

VDDIO, VDDLCD = 3.3V

TA = 25°C

CL = 50pF (Bus/CPU Interface)

CL = 0pF (LCD Panel Interface)

9.1 Clock Timing

Table 9-1: Clock Input Requirements for CLK (PLL-bypass)

Symbol	Parameter	Min	Max	Units
FCLK	Input Clock Frequency (CLK)		110	MHz
TCLK	Input Clock period (CLK)	1/fCLK		ns

Table 9-2: Clock Input Requirements for CLK

Symbol	Parameter	Min	Max	Units
FCLK	Input Clock Frequency (CLK)	2.5	50	MHz
TCLK	Input Clock period (CLK)	1/fCLK		ns

Table 9-3: Clock Input Requirements for crystal oscillator XTAL

Symbol	Parameter	Min	Max	Units
FXTAL	Input Clock Frequency	2.5	10	MHz
TXTAL	Input Clock period	1/fXTAL		ns

9.2 MCU Interface Timing

9.2.1 Parallel 6800-series Interface Timing

Table 9-4: Parallel 6800-series Interface Timing Characteristics (Use CS# as clock)

Symbol	Parameter	Min	Typ	Max	Unit
fMCLK	System Clock Frequency*	1	-	110	MHz
tMCLK	System Clock Period*	1/fMCLK	-	-	ns
tPWCSH	Control Pulse High Width	Write	13	1.5* tMCLK	ns
		Read	30	3.5* tMCLK	
tPWCSL	Control Pulse Low Width	Write (next write cycle)	13	1.5* tMCLK	ns
		Write (next read cycle)	80	9* tMCLK	
		Read	80	9* tMCLK	
tAS	Address Setup Time	2	-	-	ns
tAH	Address Hold Time	2	-	-	ns
tDSW	Data Setup Time	4	-	-	ns
tDHW	Data Hold Time	1	-	-	ns
tPLW	Write Low Time	14	-	-	ns
tPHW	Write High Time	14	-	-	ns
tPLWR	Read Low Time	38	-	-	ns
tACC	Data Access Time	32	-	-	ns
tDHR	Output Hold time	1	-	-	ns
tR	Rise Time	-	-	0.5	ns
tF	Fall Time	-	-	0.5	ns

* System Clock denotes external input clock (PLL-bypass) or internal generated clock (PLL-enabled)

Figure 9-1: Parallel 6800-series Interface Timing Diagram (Use CS# as Clock)

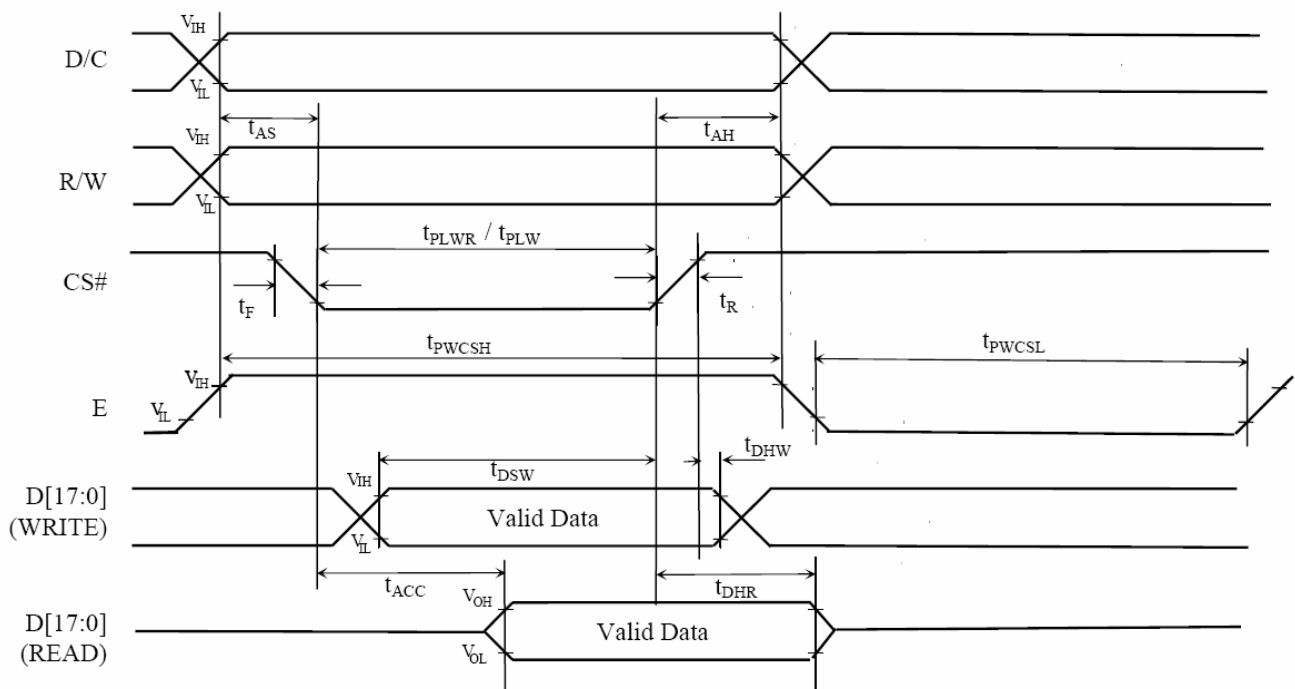
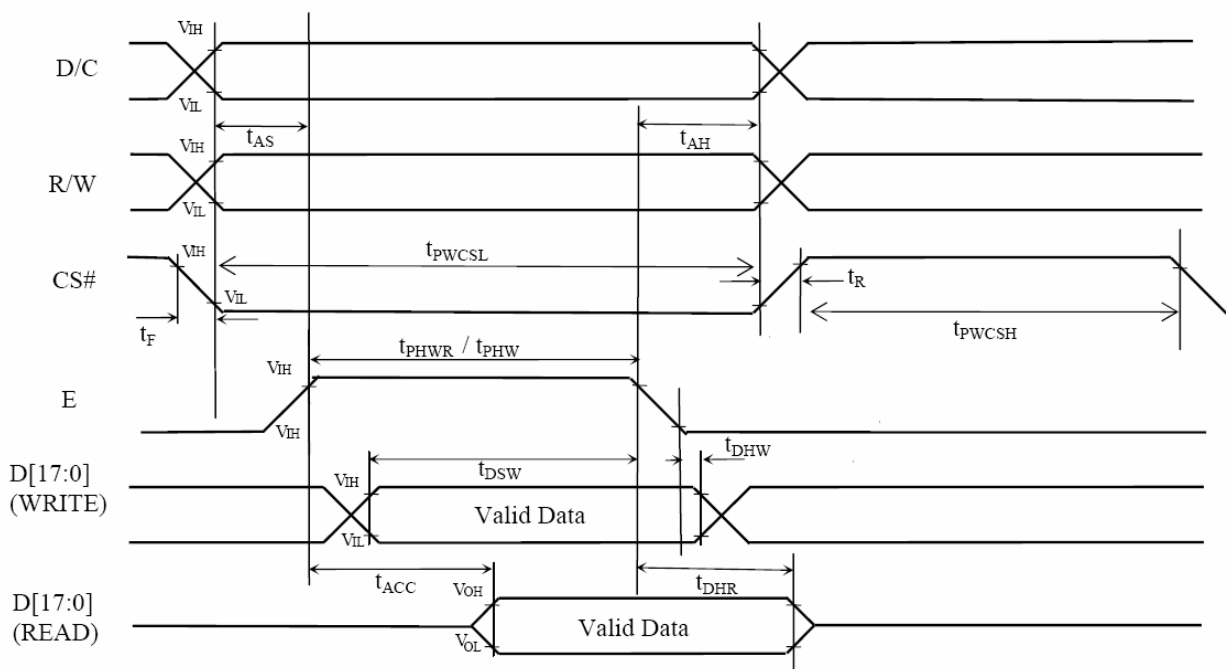

Table 9-5: Parallel 6800-series Interface Timing Characteristics (Use E as clock)

Symbol	Parameter	Min	Typ	Max	Unit
fMCLK	System Clock Frequency*	1	-	110	MHz
tMCLK	System Clock Period*	1/fMCLK	-	-	ns
tPWCSH	Control Pulse Low Width	Write (next write cycle)	13	1.5* tMCLK	-
		Write (next read cycle)	80	9* tMCLK	
		Read	80	9* tMCLK	
tPWCSL	Control Pulse High Width	Write	13	1.5* tMCLK	-
		Read	30	3.5* tMCLK	
tAS	Address Setup Time	2	-	-	ns
tAH	Address Hold Time	2	-	-	ns
tDSW	Data Setup Time	4	-	-	ns
tDHW	Data Hold Time	1	-	-	ns
tPLW	Write Low Time	14	-	-	ns
tPHW	Write High Time	14	-	-	ns
tPLWR	Read Low Time	38	-	-	ns
tACC	Data Access Time	32	-	-	ns
tDHR	Output Hold time	1	-	-	ns
tR	Rise Time	-	-	0.5	ns
tF	Fall Time	-	-	0.5	ns

* System Clock denotes external input clock (PLL-bypass) or internal generated clock (PLL-enabled)

Figure9-2: Parallel 6800-series Interface Timing Diagram (Use E as Clock)



9.2.2 Parallel 8080-series Interface Timing

Table 9-6: Parallel 8080-series Interface

Symbol	Parameter	Min	Typ	Max	Unit
fMCLK	System Clock Frequency*	1	-	110	MHz
tMCLK	System Clock Period*	1/ fMCLK	-	-	ns
tPWCSL	Control Pulse High Width	13	1.5* tMCLK	-	ns
	Write	30	3.5* tMCLK	-	ns
	Read				
tPWCSH	Control Pulse Low Width	13	1.5* tMCLK	-	ns
	Write (next write cycle)	80	9* tMCLK	-	ns
	Write (next read cycle)	80	9* tMCLK	-	ns
tAS	Address Setup Time	1	-	-	ns
tAH	Address Hold Time	2	-	-	ns
tDSW	Write Data Setup Time	4	-	-	ns
tDHW	Write Data Hold Time	1	-	-	ns
tPWLW	Write Low Time	12	-	-	ns
tDHR	Read Data Hold Time	1	-	-	ns
tACC	Access Time	32	-	-	ns
tPWLR	Read Low Time	36	-	-	ns
tR	Rise Time	-	-	0.5	ns
tF	Fall Time	-	-	0.5	ns
tCS	Chip select setup time	2	-	-	ns
tCSH	Chip select hold time to read signal	3	-	-	ns

* System Clock denotes external input clock (PLL-bypass) or internal generated clock (PLL-enabled)

Figure 9-3: Parallel 8080-series Interface Timing Diagram (Write Cycle)

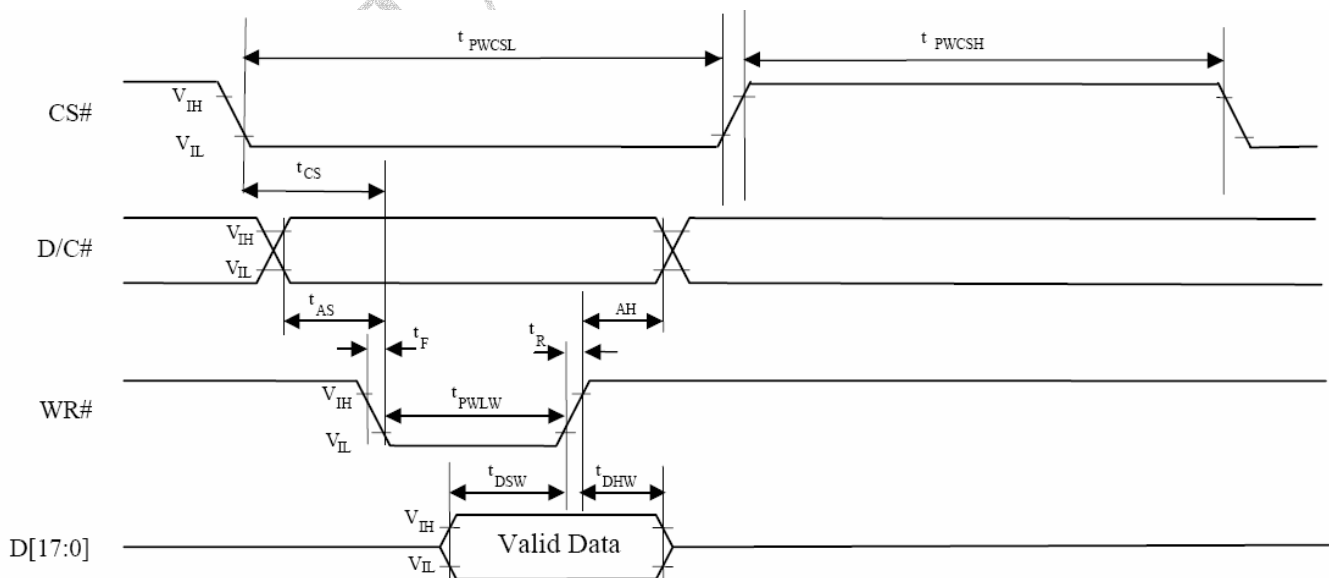
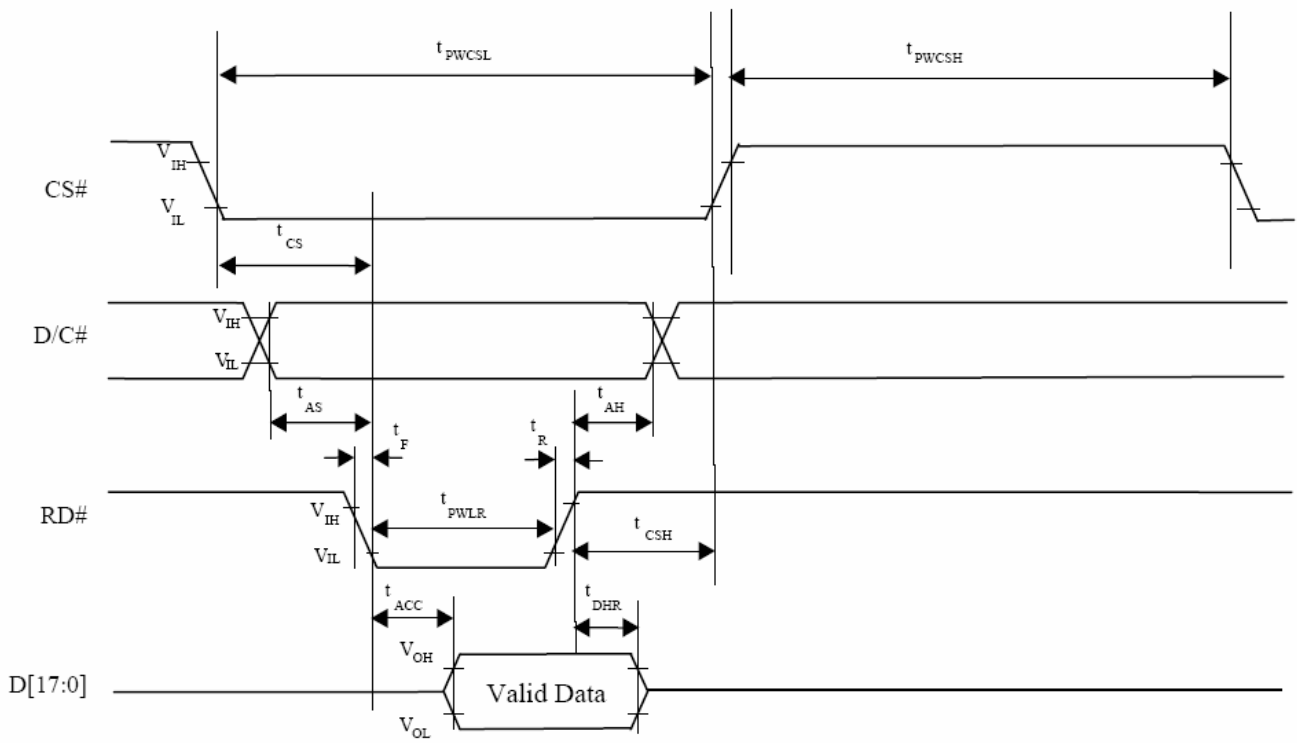

Figure 9-4: Parallel 8080-series Interface Timing Diagram (Read Cycle)



RAYSTAR 01

10. Backlight Information

Parameter	Symbol	Min.	Typ.	Max.	Unit	Remark
LED current	I _{LED}	-	160	-	mA	Note 1
LED voltage	V _{LED}	-	9.9	-	V	
LED Life Time	-	10,000	20,000	-	Hr	Note 2

Note 1 : There are 8 Groups LED shown as below , V_{LED}=9.9V , I_{LED}=160mA.

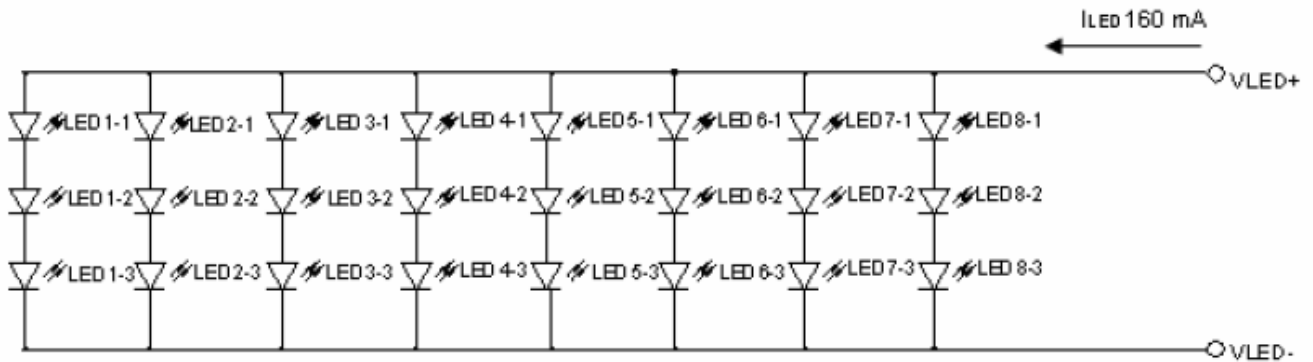

Note 2 : Brightness to be decreased to 50% of the initial value.

11. Reliability Test

WIDE TEMPERATURE RELIABILITY TEST

NO	ITEM	CONDITION			STANDARD	NOTE
1	High Temp. Storage	80°C	240 Hrs		Appearance without defect	
2	Low Temp. Storage	-30°C	240 Hrs		Appearance without defect	
3	High Temp. & High Humi. Storage	60 °C 90%RH	240 Hrs		Appearance without defect	
4	High Temp. Operating Display	70°C	240 Hrs		Appearance without defect	
5	Low Temp. Operating Display	-20°C	240 Hrs		Appearance without defect	
6	Thermal Shock	-20 °C, 30min. → 70°C, 30min. (cycle)			Appearance without defect	10 cycles

Inspection Provision

1. Purpose

The RAYSTAR inspection provision provides outgoing inspection provision and its expected quality level based on our outgoing inspection of RAYSTAR LCD produces.

2. Applicable Scope

The RAYSTAR inspection provision is applicable to the arrangement in regard to outgoing inspection and quality assurance after outgoing.

3. Technical Terms

3-1 RAYSTAR Technical Terms



4. Outgoing Inspection

4-1 Inspection Method

MIL-STD-105E Level II Regular inspection

4-2 Inspection Standard

	Item	AQL(%)	Remarks
Major Defect	Dots Opens Shorts Erroneous operation	0.4	Faults which substantially lower the practicality and the initial purpose difficult to achieve
	Solder appearance Shorts Loose		
	Cracks Display surface cracks		

	Dimensions	External from Dimensions	AQL	Remarks
Minor Defect	Inside the glass	Black spots	0.65	Faults which appear to pose almost no obstacle to the practicality, effective use, and operation
	Polarizing plate	Scratches, foreign Matter, air bubbles, and peeling		
	Dots	Pinhole, deformation		
	Color tone	Color unevenness		
	Solder appearance	Cold solder Solder projections		

4-3 Inspection Provisions

*Viewing Area Definition

Fig. 1

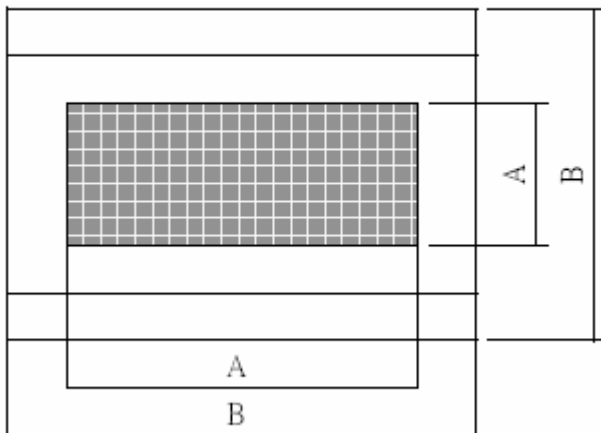

A : Zone Viewing Area

B : Zone Glass Plate Outline

*Inspection place to be 500 to 1000 lux illuminance uniformly without glaring.

The distance between luminous source(daylight fluorescent lamp and cool white fluorescent lamp)

and sample to be 30 cm to 50 cm.

*Test and measurement are performed under the following conditions, unless otherwise specified.

Temperature $20 \pm 15^{\circ}\text{C}$

Humidity $65 \pm 20\%\text{R.H.}$

Pressure 860~1060hPa(mmbar)

In case of doubtful judgment, it is performed under the following conditions.

Temperature $20 \pm 2^{\circ}\text{C}$

Humidity $65 \pm 5\%\text{R.H.}$

Pressure 860~1060hPa(mmbar)

5.Specification for quality check

5-1-1 Electrical characteristics :

NO.	Item	Criterion
1	Non operational	Fail
2	Miss operating	Fail
3	Contrast irregular	Fail
4	Response time	Within Specified value

5-1-2 Components soldering :

Should be no defective soldering such as shorting, loose terminal cold solder, peeling of printed circuit board pattern, improper mounting position, etc.

5-2 Inspection Standard for TFT panel

5-2-1 The environmental condition of inspection :

The environmental condition and visual inspection shall be conducted as below.

(1) Ambient temperature : $25\pm 5^{\circ}\text{C}$

(2) Humidity : 25~75% RH

(3) External appearance inspection shall be conducted by using a single 20W fluorescent lamp or equivalent illumination.

(4) Visual inspection on the operation condition for cosmetic shall be conducted at the distance 30cm or more between the LCD panels and eyes of inspector. The viewing angle shall be 90 degree to the front surface of display panel.

(5) Ambient Illumination : 300~500 Lux for external appearance inspection.

(6) Ambient Illumination : 100~200 Lux for light on inspection.

5-2-2 Inspection Criteria

(1) Definition of dot defect induced from the panel inside

a) The definition of dot : The size of a defective dot over 1/2 of whole dot is regarded as one defective dot

b) Bright dot : Dots appear bright and unchanged in size in which LCD panel is displaying under black pattern.

c) Dark dot : Dots appear dark and unchanged in size in which LCD panel is displaying under pure red, green, blue pattern.

d) 2 dot adjacent = 1 pair = 2 dots

Picture :

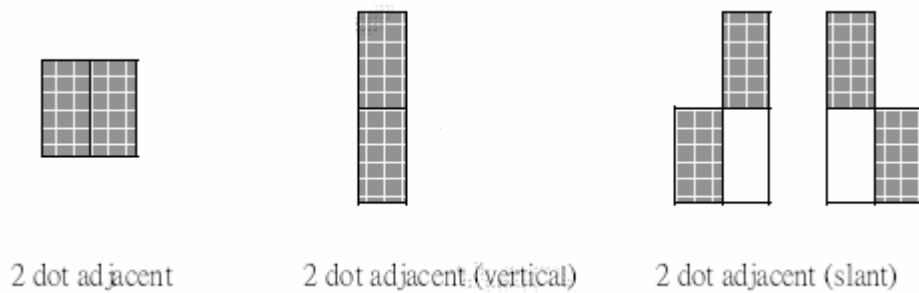

(2) Display Inspection

NO.	Item		Acceptable Count	
1	Dot defect	Bright Dot	Random	$N \leq 2$
			2 dots adjacent	$N \leq 0$
		Dark Dot	Random	$N \leq 3$
			2 dots adjacent	$N \leq 1$
	Total bright and dark dot			$N \leq 4$
Functional failure (V-line/ H-line/Cross line etc.)			Not allowable	
	Mura	It's OK if mura is slight visible through 6% ND filter. (Judged by limit sample if it is necessary)		
2	Newton ring (touch panel)	Orbicular of interference fringes is not allowed in the optimum contrast within the active area under viewing angle.		

(3) Appearance inspection

NO.	Item	Standards
1	Panel Crack	Not allow. It is shown in Fig.1.
2	Broken CF Non -lead Side of TFT	The broken in the area of $W > 2\text{mm}$ is ignored, L is ignored. It is shown in Fig.2.
3	Broken Lead Side of TFT	FPC lead, electrical line or alignment mark can't be damaged. It is shown in Fig.3.
4	Broken Corner of TFT at Lead Side	FPC lead. electrical line or alignment mark can't be damaged. It is shown in Fig.4.
5	Burr of TFT / CF Edge	The distance of burr from the edge of TFT / CF, $W \leq 0.3\text{mm}$. It is shown in Fig.5.
6	Foreign Black / White/Bright Spot	(1) $0.15 < D \leq 0.5 \text{ mm}$, $N \leq 4$; (2) $D \leq 0.15\text{mm}$, Ignore. It is shown in Fig.6.
7	Foreign Black / White/Bright Line	(1) $0.05 < W \leq 0.1 \text{ mm}$, $0.3 < L \leq 2 \text{ mm}$, $N \leq 4$.
		(2) $W \leq 0.05\text{mm}$ and $L \leq 0.3\text{mm}$ Ignore. It is shown in Fig.7.
8	Color irregular	Not remarkable color irregular.

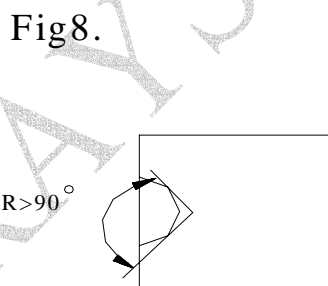
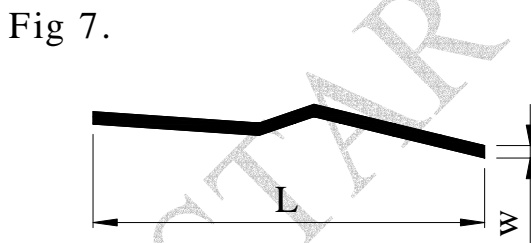
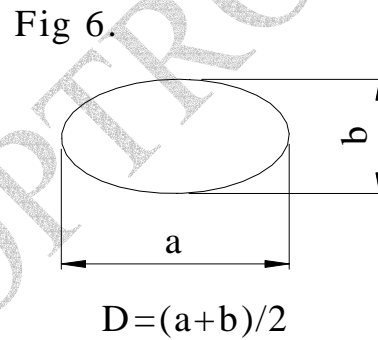
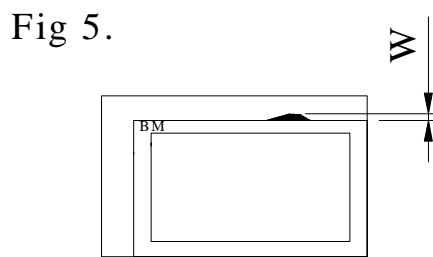
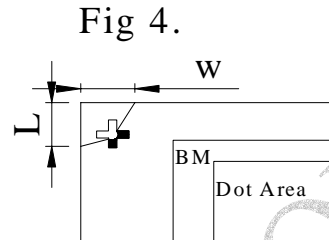
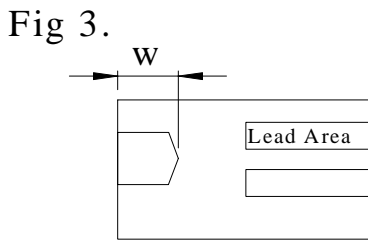
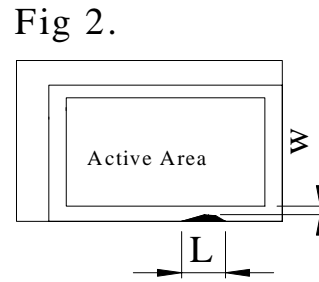
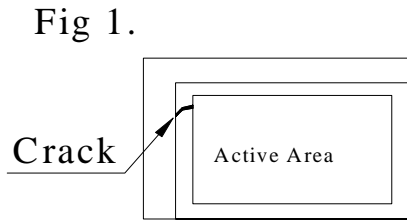

Notes

1.W:Width

2.Length

3.D:Average Diameter

4.N:Count

5.All the anhle of the broken must be larger than 90° .It is shown in Fig.8.($R > 90^\circ$ ~)

NOTICE:

- SAFETY

1. If the LCD panel breaks, be careful not to get the liquid crystal to touch your skin.
2. If the liquid crystal touches your skin or clothes, please wash it off immediately by using soap and water.

- HANDLING

1. Avoid static electricity which can damage the CMOS LSI.
2. Do not remove the panel or frame from the module.
3. The polarizing plate of the display is very fragile. So, please handle it very carefully.
4. Do not wipe the polarizing plate with a dry cloth, as it may easily scratch the surface of plate.
5. Do not use ketonics solvent & Aromatic solvent. Use a soft cloth soaked with a cleaning naphtha solvent.

- STORAGE

1. Store the panel or module in a dark place where the temperature is $25\pm 5^{\circ}\text{C}$ and the humidity is below 65% RH.
2. Do not place the module near organics solvents or corrosive gases.
3. Do not crush, shake, or jolt the module.

- TERMS OF WARRANT

1. Acceptance inspection period

The period is within one month after the arrival of contracted commodity at the buyer's factory site.

2. Applicable warrant period

The period is within twelve months since the date of shipping out under normal using and storage conditions.

LCM Sample Estimate Feedback Sheet

Module Number : _____

1 、 Panel Specification :

1. Panel Type :	<input type="checkbox"/> Pass	<input type="checkbox"/> NG , _____
2. View Direction :	<input type="checkbox"/> Pass	<input type="checkbox"/> NG , _____
3. Numbers of Dots :	<input type="checkbox"/> Pass	<input type="checkbox"/> NG , _____
4. View Area :	<input type="checkbox"/> Pass	<input type="checkbox"/> NG , _____
5. Active Area :	<input type="checkbox"/> Pass	<input type="checkbox"/> NG , _____
6. Operating Temperature :	<input type="checkbox"/> Pass	<input type="checkbox"/> NG , _____
7. Storage Temperature :	<input type="checkbox"/> Pass	<input type="checkbox"/> NG , _____
8. Others :	_____	

2 、 Mechanical Specification :

1. PCB Size :	<input type="checkbox"/> Pass	<input type="checkbox"/> NG , _____
2. Frame Size :	<input type="checkbox"/> Pass	<input type="checkbox"/> NG , _____
3. Material of Frame :	<input type="checkbox"/> Pass	<input type="checkbox"/> NG , _____
4. Connector Position :	<input type="checkbox"/> Pass	<input type="checkbox"/> NG , _____
5. Fix Hole Position :	<input type="checkbox"/> Pass	<input type="checkbox"/> NG , _____
6. Backlight Position :	<input type="checkbox"/> Pass	<input type="checkbox"/> NG , _____
7. Thickness of PCB :	<input type="checkbox"/> Pass	<input type="checkbox"/> NG , _____
8. Height of Frame to PCB :	<input type="checkbox"/> Pass	<input type="checkbox"/> NG , _____
9. Height of Module :	<input type="checkbox"/> Pass	<input type="checkbox"/> NG , _____
10. Others :	<input type="checkbox"/> Pass	<input type="checkbox"/> NG , _____

3 、 Relative Hole Size :

1. Pitch of Connector :	<input type="checkbox"/> Pass	<input type="checkbox"/> NG , _____
2. Hole size of Connector :	<input type="checkbox"/> Pass	<input type="checkbox"/> NG , _____
3. Mounting Hole size :	<input type="checkbox"/> Pass	<input type="checkbox"/> NG , _____
4. Mounting Hole Type :	<input type="checkbox"/> Pass	<input type="checkbox"/> NG , _____
5. Others :	<input type="checkbox"/> Pass	<input type="checkbox"/> NG , _____

4 、 Backlight Specification :

1. B/L Type :	<input type="checkbox"/> Pass	<input type="checkbox"/> NG , _____
2. B/L Color :	<input type="checkbox"/> Pass	<input type="checkbox"/> NG , _____
3. B/L Driving Voltage (Reference for LED Type) :	<input type="checkbox"/> Pass	<input type="checkbox"/> NG , _____
4. B/L Driving Current :	<input type="checkbox"/> Pass	<input type="checkbox"/> NG , _____
5. Brightness of B/L :	<input type="checkbox"/> Pass	<input type="checkbox"/> NG , _____
6. B/L Solder Method :	<input type="checkbox"/> Pass	<input type="checkbox"/> NG , _____
7. Others :	<input type="checkbox"/> Pass	<input type="checkbox"/> NG , _____

>> Go to page 2 <<

Module Number : _____

5 、 Electronic Characteristics of Module :		
1.Input Voltage :	<input type="checkbox"/> Pass	<input type="checkbox"/> NG , _____
2.Supply Current :	<input type="checkbox"/> Pass	<input type="checkbox"/> NG , _____
3.Driving Voltage for LCD :	<input type="checkbox"/> Pass	<input type="checkbox"/> NG , _____
4.Contrast for LCD :	<input type="checkbox"/> Pass	<input type="checkbox"/> NG , _____
5.B/L Driving Method :	<input type="checkbox"/> Pass	<input type="checkbox"/> NG , _____
6.Negative Voltage Output :	<input type="checkbox"/> Pass	<input type="checkbox"/> NG , _____
7.Interface Function :	<input type="checkbox"/> Pass	<input type="checkbox"/> NG , _____
8.LCD Uniformity :	<input type="checkbox"/> Pass	<input type="checkbox"/> NG , _____
9.ESD test :	<input type="checkbox"/> Pass	<input type="checkbox"/> NG , _____
10.Others :	<input type="checkbox"/> Pass	<input type="checkbox"/> NG , _____

6 、 Summary :

RAYSTAR OPTRONICS

Sales signature : _____

Customer Signature : _____

Date : / /